

## Nominal data

Type	7114 NH	
Nominal voltage	VDC	24
Nominal voltage range	VDC	12 .. 26.5
Speed	min <sup>-1</sup>	3350
Power input	W	19.0
Min. ambient temperature	°C	-25
Max. ambient temperature	°C	72
Air flow	m <sup>3</sup> /h	360
Sound power level	B	6.7
Sound pressure level	dB(A)	58

ml = Max. load · me = Max. efficiency · fa = Running at free air · cs = Customer specs · cu = Customer unit  
Subject to alterations

7114 NH

## DC axial compact fan

### Technical features

<b>General description</b>	* Free air power consumption, these values may be considerably higher at the operating point.
<b>Mass</b>	0.620 kg
<b>Dimensions</b>	150 Ø x 38 mm
<b>Material of impeller</b>	Sheet steel, coated in black
<b>Housing material</b>	Die-cast aluminium
<b>Direction of air flow</b>	Air exhaust over bars
<b>Direction of rotation</b>	Left, looking at rotor
<b>Bearing</b>	Ball bearings
<b>Lifetime L10 at 40 °C</b>	75000 h
<b>Lifetime L10 at maximum temperature</b>	35000 h
<b>Connection line</b>	Single strands AWG 22, TR 64, bared and tin-plated.
<b>Motor protection</b>	Protected against reverse polarity and locking.
<b>Locked-rotor protection</b>	Electronic blocking protection
<b>Approval</b>	VDE, CSA, UL, CE

7114 NH

# DC axial compact fan

## Product drawing

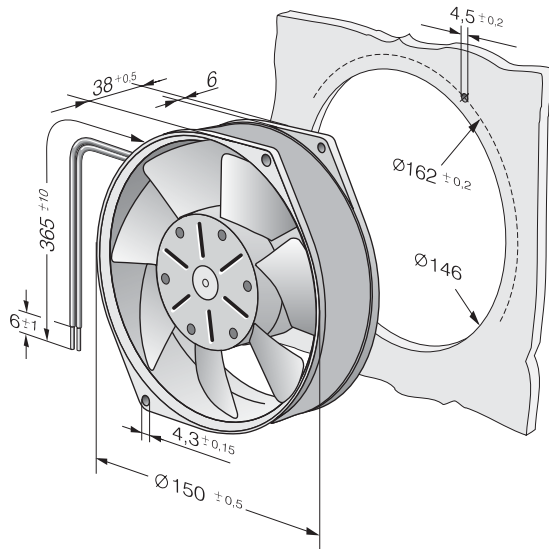

Charts: Air flow

